

Chapter 3. Building Blocks

301 General

301.1 Scope. The provisions of this chapter shall apply where required by the scoping provisions adopted by the administrative authority or by Chapters 4 through 10.

302 Floor or Ground Surfaces

302.1 General. Floor or ground surfaces shall be stable, firm, and slip resistant, and shall comply with Section 302. Changes in level in floor or ground surfaces shall comply with Section 303.

302.2 Carpet. Carpet or carpet tile shall be securely attached and shall have a firm cushion, pad, or backing or no cushion or pad. Carpet or carpet tile shall have a level loop, textured loop, level cut pile, or level cut/uncut pile texture. Pile height shall be 1/2 inch (13 mm) maximum. Exposed edges of carpet shall be fastened to floor or ground surfaces and shall have trim along the entire length of the exposed edge. Carpet edge trim shall comply with Section 303.



Fig. 302.2
Carpet on Floor or Ground Surfaces

302.3 Openings. Openings in floor or ground surfaces shall be of a size that does not permit the passage of a 1/2 inch (13 mm) diameter sphere, except as allowed in Sections 407 and 408. Elongated openings shall be placed so that the long dimension is perpendicular to the dominant direction of travel.

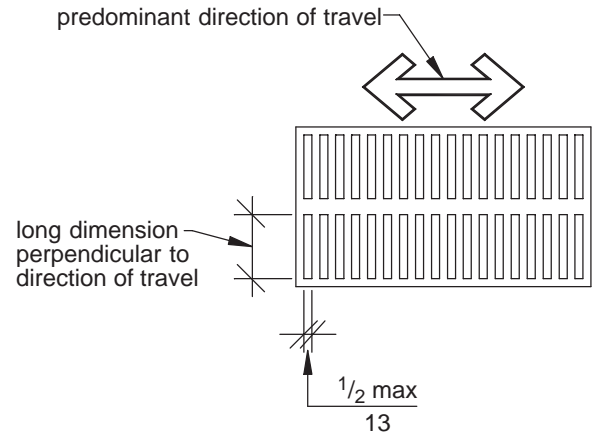

Fig. 302.3
Openings in Floor or Ground Surfaces



Fig. 303.2
Vertical Changes in Level

303 Changes in Level

303.1 General. Changes in level in floor or ground surfaces shall comply with Section 303.

303.2 Vertical. Changes in level of 1/4 inch (6 mm) high maximum shall be permitted to be vertical.

303.3 Beveled. Changes in level between 1/4 inch (6 mm) high minimum and 1/2 inch (13 mm) high maximum shall be beveled with a slope not steeper than 1:2.

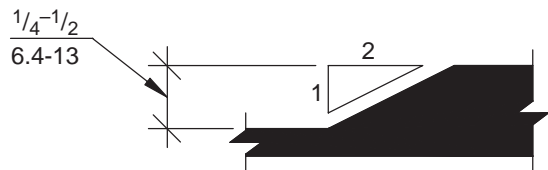

Fig. 303.3
Beveled Changes in Level

303.4 Ramped. Changes in level greater than 1/2 inch (13 mm) shall be ramped and shall comply with Section 405 or 406.

304 Wheelchair Turning Space

304.1 General. A wheelchair turning space shall comply with Section 304.

304.2 Floor or Ground Surface. Floor or ground surfaces of a wheelchair turning space shall have a slope not steeper than 1:48 and shall comply with Section 302.

304.3 Size. Wheelchair turning space shall comply with Section 304.3.1 or 304.3.2.

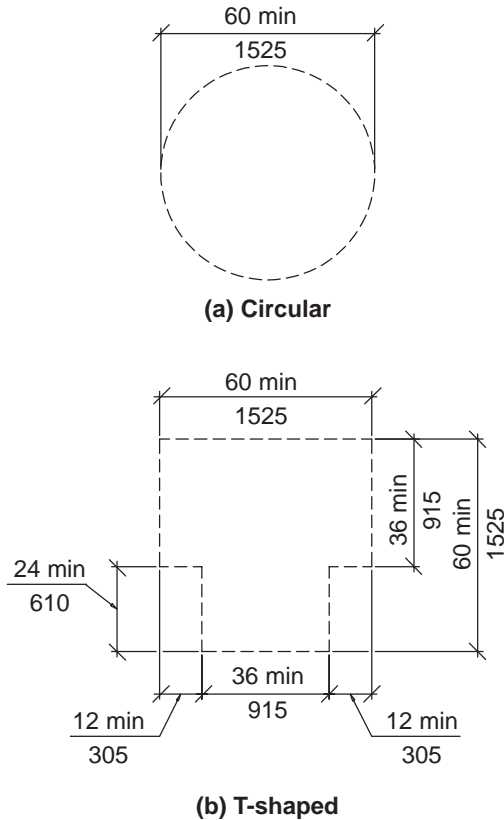

Fig. 304.3
Size of Wheelchair Turning Space

304.3.1 Circular Space. The wheelchair turning space shall be not less than 60 inches (1525 mm) diameter minimum. Wheelchair turning space shall be permitted to include knee and toe clearance complying with Section 306.

304.3.2 T-Shaped Space. The wheelchair turning space shall be a T-shaped space within a 60 inch (1525 mm) minimum square with arms and base 36 inches (915 mm) wide minimum. Each arm of the T shall be clear of obstructions 12 inches (305 mm) minimum in each direction and the base shall be clear of obstructions 24 inches (610 mm) minimum. T-shaped wheelchair turning spaces shall be permitted to

include knee and toe clearance complying with Section 306 only at the end of either the base or one arm.

304.4 Doors. Unless otherwise specified, doors shall be permitted to swing into wheelchair turning spaces.

305 Clear Floor or Ground Space

305.1 General. Clear floor or ground space shall comply with Section 305.

305.2 Floor or Ground Surfaces. Floor or ground surfaces of a clear floor or ground space shall have a slope not steeper than 1:48 and shall comply with Section 302.

305.3 Size. The clear floor or ground space shall be 30 inches (760 mm) minimum by 48 inches (1220 mm) minimum.

305.4 Knee and Toe Clearance. Unless otherwise specified, clear floor or ground space shall be permitted to include knee and toe clearance complying with Section 306.

305.5 Position. Unless otherwise specified, the clear floor or ground space shall be positioned for either forward or parallel approach to an element.

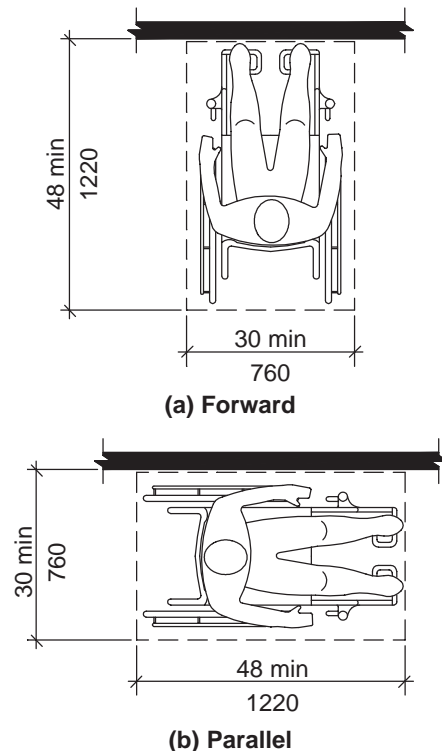
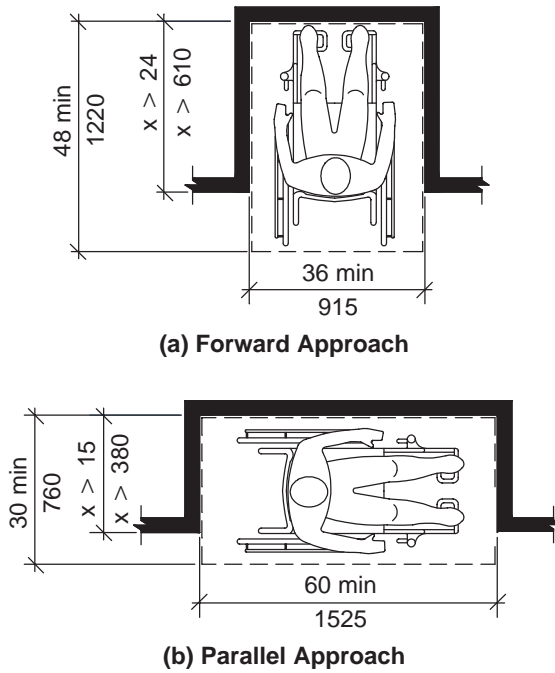

Fig. 305.5
Position of Clear Floor or Ground Space

305.6 Approach. One full unobstructed side of the clear floor or ground space shall adjoin or overlap an accessible route or adjoin another clear floor or ground space.

305.7 Maneuvering Clearance. If a clear floor or ground space is in an alcove or otherwise confined on all or part of three sides, additional maneuvering clearances complying with Sections 305.7.1 and 305.7.2 shall be provided.



(a) Forward Approach

(b) Parallel Approach

Fig. 305.7
Maneuvering Clearance in an Alcove

305.7.1 Forward Approach. The width of an alcove shall be 36 inches (915 mm) minimum where the depth exceeds 24 inches (610 mm).

305.7.2 Parallel Approach. The width of an alcove shall be 60 inches (1525 mm) minimum where the depth exceeds 15 inches (380 mm).

306 Knee and Toe Clearance

306.1 General. Where space beneath an element is included as part of clear floor or ground space at an element, clearance at an element, or a wheelchair turning space, the space shall comply with Section 306. Additional space beyond knee and toe clearance shall be permitted beneath elements.

306.2 Toe Clearance.

306.2.1 General. Space under an element between the floor or ground and 9 inches (230

mm) above the floor or ground shall be toe clearance and shall comply with Section 306.2.

306.2.2 Maximum Depth. Toe clearance shall be permitted to extend 25 inches (635 mm) maximum under an element.

306.2.3 Minimum Depth. Where toe clearance is required at an element as part of a clear floor or ground space, the toe clearance shall extend 17 inches (430 mm) minimum beneath the element.

306.2.4 Additional Clearance. Space extending greater than 6 inches (150 mm) beyond the available knee clearance at 9 inches (230 mm) above the floor or ground shall not be included in toe clearance.

306.2.5 Width. Toe clearance shall be 30 inches (760 mm) wide minimum.

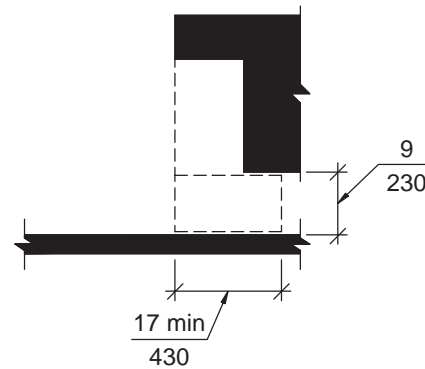

Fig. 306.2
Toe Clearance

306.3 Knee Clearance.

306.3.1 General. Space under an element between 9 inches (230 mm) and 27 inches (685 mm) above the floor or ground shall be knee clearance and shall comply with Section 306.3.

306.3.2 Maximum Depth. Knee clearance shall be permitted to extend 25 inches (635 mm) maximum under an element at 9 inches (230 mm) above the floor or ground.

306.3.3 Minimum Depth. Where knee clearance is required beneath an element as part of a clear floor or ground space, the knee clearance shall be 11 inches (280 mm) deep minimum at 9 inches (230 mm) above the floor or ground, and 8 inches (205 mm) deep minimum at 27 inches (685 mm) above the floor or ground.

306.3.4 Clearance Reduction. Between 9 inches (230 mm) and 27 inches (685 mm) above

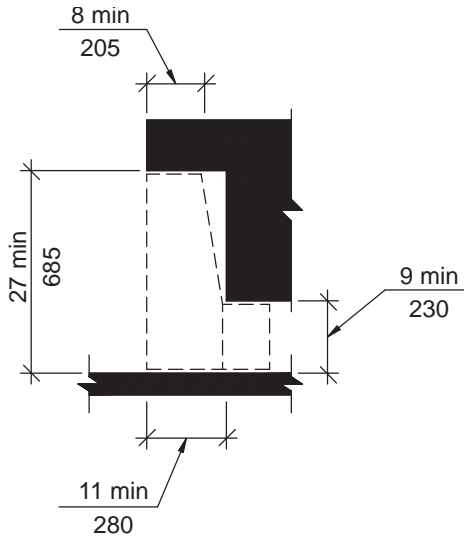

Fig. 306.3
Knee Clearance

the floor or ground, the knee clearance shall be permitted to be reduced at a rate of 1 inch (26 mm) for each 6 inches (150 mm) in height.

306.3.5 Width. Knee clearance shall be 30 inches (760 mm) wide minimum.

307 Protruding Objects

307.1 General. Protruding objects on circulation paths shall comply with Section 307.

307.2 Protrusion Limits. Objects with leading edges more than 27 inches (685 mm) and not more than 80 inches (2030 mm) above the floor or ground shall protrude 4 inches (100 mm) maximum horizontally into the circulation path.

EXCEPTION: Handrails serving stairs and ramps shall be permitted to protrude 4 1/2 inches (115 mm) maximum.

307.3 Post-Mounted Objects. Objects on a single post or pylon shall be permitted to overhang 12 inches (305 mm) maximum where more than 27 inches (685 mm) and not more than 80 inches (2030 mm) above the floor or ground. Objects on multiple posts or pylons where the clear distance between the posts or pylons is greater than 12 inches (305 mm), shall have the lowest edge of such object either 27 inches (685 mm) maximum or 80 inches (2030 mm) minimum above the floor or ground surface.

EXCEPTION: Sloping portions of handrails serving stairs and ramps.

307.4 Reduced Vertical Clearance. Guardrails or other barriers shall be provided where vertical

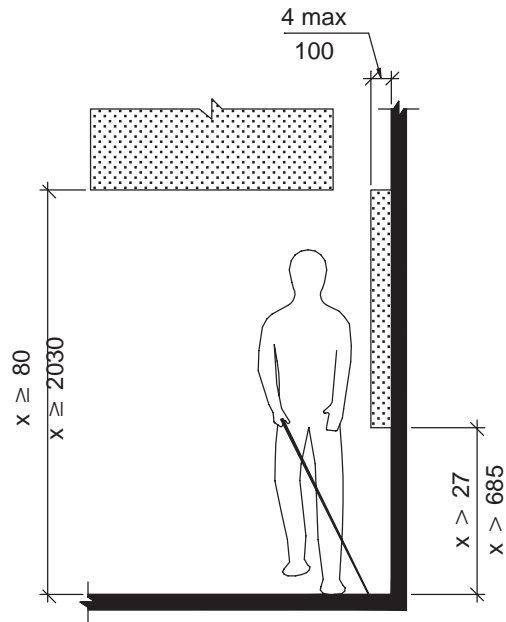

Fig. 307.2
Limits of Protruding Objects

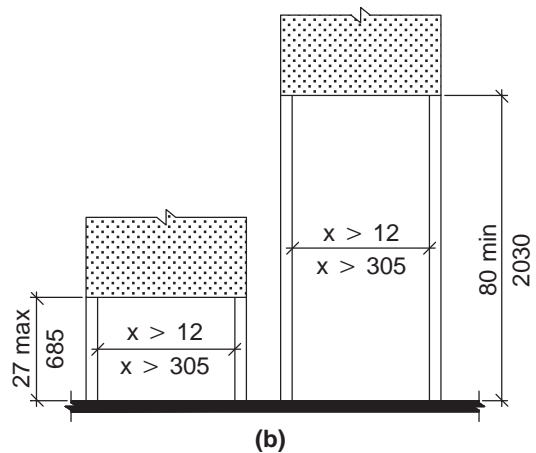
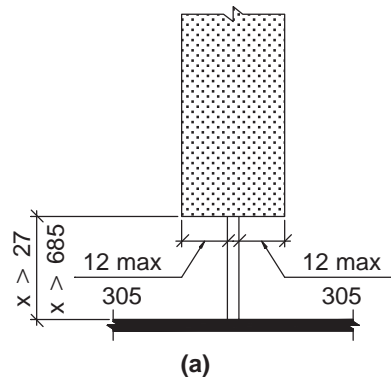

Fig. 307.3
Post-Mounted Protruding Objects

clearance is less than 80 inches (2030 mm) high. Leading edge of such guardrail or barrier shall be 27 inches (685 mm) maximum above the floor or ground.

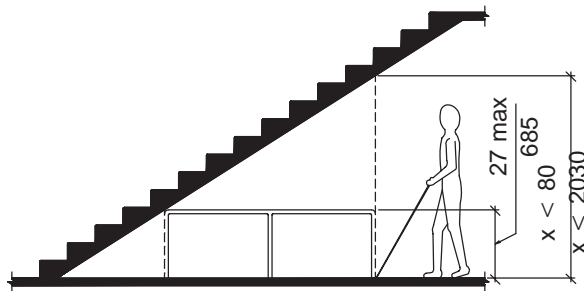

Fig. 307.4
Reduced Vertical Clearance

307.5 Required Clear Width. Protruding objects shall not reduce the clear width required for accessible routes.

308 Reach Ranges

308.1 General. Reach ranges shall comply with Section 308.

308.2 Forward Reach.

308.2.1 Unobstructed. Where a forward reach is unobstructed, the high forward reach shall be 48 inches (1220 mm) maximum and the low forward reach shall be 15 inches (380 mm) minimum above the floor or ground.

308.2.2 Obstructed High Reach. Where a high forward reach is over an obstruction, the

clear floor or ground space shall extend beneath the element for a distance not less than the required reach depth over the obstruction. The high forward reach shall be 48 inches (1220 mm) maximum where the reach depth is 20 inches (510 mm) maximum. Where the reach depth exceeds 20 inches (510 mm) maximum, the high forward reach shall be 44 inches (1120 mm) maximum and the reach depth shall be 25 inches (635 mm) maximum.

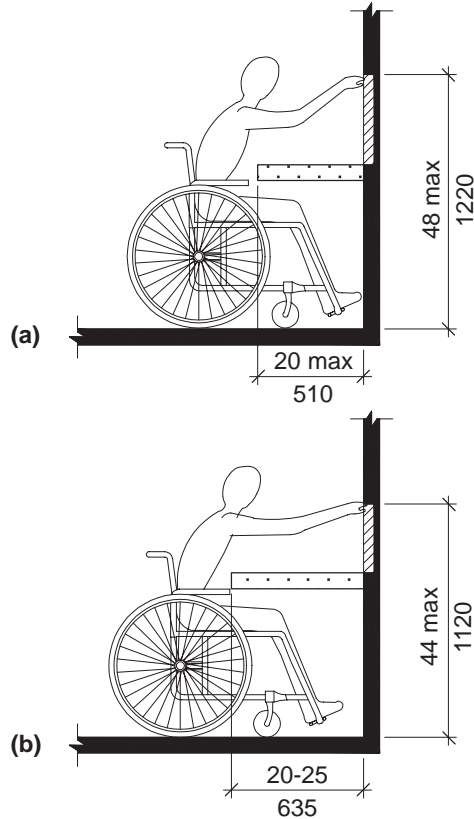

Fig. 308.2.2
Obstructed High Forward Reach

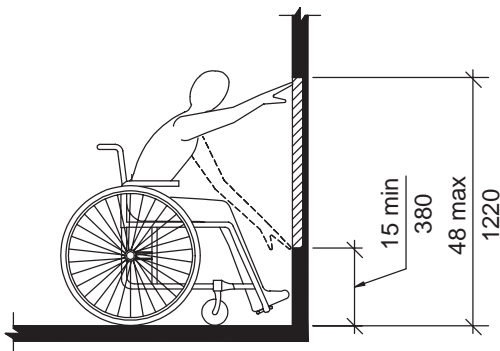

Fig. 308.2.1
Unobstructed Forward Reach

308.3 Side Reach.

308.3.1 Unobstructed. Where a clear floor or ground space allows a parallel approach to an element and the side reach is unobstructed, the high side reach shall be 48 inches (1220 mm) maximum and the low side reach shall be 15 inches (380 mm) minimum above the floor or ground.

EXCEPTION: Existing elements shall be permitted at 54 inches (1370 mm) maximum above the floor or ground.

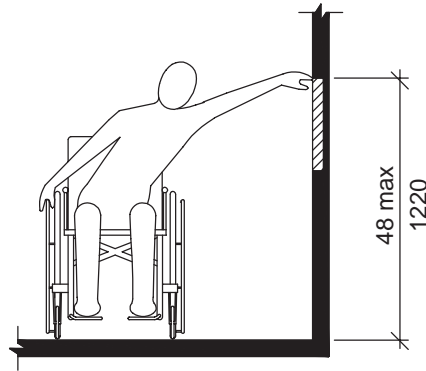

Fig. 308.3.1
Unobstructed Side Reach

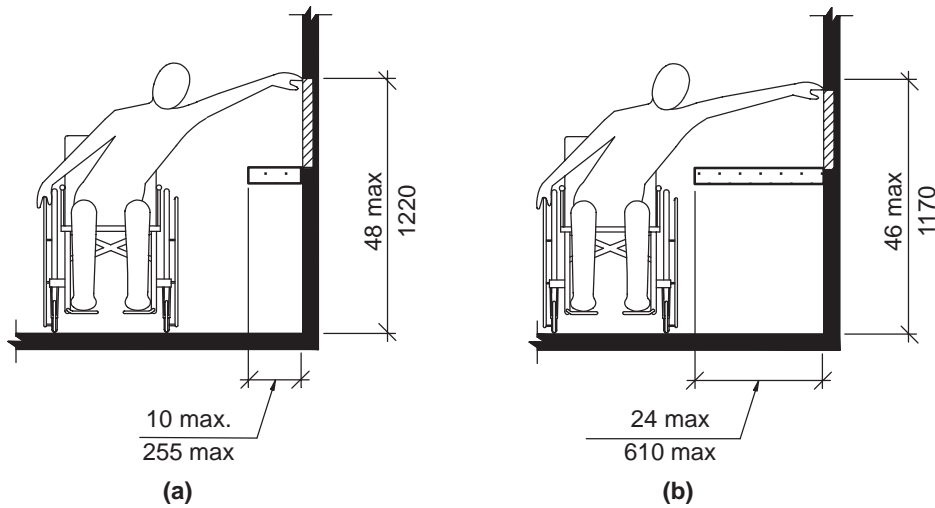

Fig. 308.3.2
Obstructed High Side Reach

308.3.2 Obstructed High Reach. Where a clear floor or ground space allows a parallel approach to an object and the high side reach is over an obstruction, the height of the obstruction shall be 34 inches (865 mm) maximum and the depth of the obstruction shall be 24 inches (610 mm) maximum. The high side reach shall be 48 inches (1220 mm) maximum for a reach depth of 10 inches (255 mm) maximum. Where the reach depth exceeds 10 inches (255 mm), the high side reach shall be 46 inches (1170 mm) maximum for a reach depth of 24 inches (610 mm) maximum.

309.2 Clear Floor or Ground Space. A clear floor or ground space complying with Section 305 shall be provided.

309.3 Height. Operable parts shall be placed within one or more of the reach ranges specified in Section 308.

EXCEPTIONS:

1. Where the use of special equipment dictates otherwise.
2. Where electrical and communications systems receptacles are not normally intended for use by building occupants.

309 Operable Parts

309.1 General. Operable parts required to be accessible shall comply with Section 309.

309.4 Operation. Operable parts shall be operable with one hand and shall not require tight grasping, pinching, or twisting of the wrist. The force required to activate operable parts shall be 5 pounds (22.2 N) maximum.